

### Parts packed with the Headboard

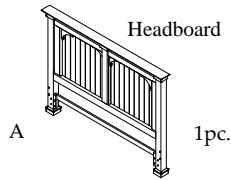

### Chalk Finish 6/0-6/6 King Size Bed Components

- 44480 -- 6/0-6/6 Panel Headboard
- 44481 -- 6/0-6/6 Panel Footboard & Slats
- 44475 -- 5/0-6/6 Panel Bed Rails (for 6/6 Bed)  
or
- 44485 -- 6/0 Panel Bed Rails (for 6/0 Bed)

6/6 Eastern King Bed

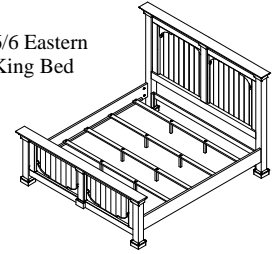

### Parts packed with the Footboard

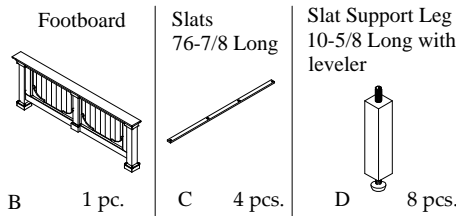

### Charcoal Finish 6/0-6/6 King Size Bed Components

- 44483 -- 6/0-6/6 Panel Headboard
- 44487 -- 6/0-6/6 Panel Footboard & Slats
- 44472 -- 5/0-6/6 Panel Bed Rails (for 6/6 Bed)  
or
- 44486 -- 6/0 Panel Bed Rails (for 6/0 Bed)

6/0 California King Bed



### Component Parts & Hardware packed with the Bed Rails

5/0-6/6 Bed Rail

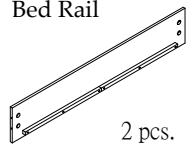

Bolt Ø5/16" x 4-1/2"L



F 8 pcs.

Curved Washer Ø5/16"



G 8 pcs.

Lock Washer Ø5/16"



H 8 pcs.

Hex Nut Ø5/16-18 Dia. x 12mm



I 8 pcs.

Open Wrench 12mm



J 1 pc.

Wood Screw #8 x 1" L.

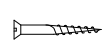

K 8 pcs.

6/0 Bed Rail

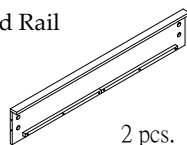

Bolt Ø5/16" x 4-1/2"L



F 8 pcs.

Curved Washer Ø5/16"



G 8 pcs.

Lock Washer Ø5/16"



H 8 pcs.

Hex Nut Ø5/16-18 Dia. x 12mm



I 8 pcs.

Open Wrench 12mm



J 1 pc.

Wood Screw #8 x 1" L.

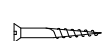

K 8 pcs.

### ASSEMBLY STEPS :

1. Gently lean the Headboard against the wall where the completed Bed will be located in the room.

2. Install the eight All-Thread Bolts (F) into the threaded metal inserts mounted on the Headboard and Footboard posts.

3. Position one end of one Bed Rail (E) onto the All-Thread Bolts and fasten with the Curved Washers (C), Lock Washers (H) and Hex Nuts (I). Only partially tighten the Hex Nuts until the Footboard has been connected. Repeat for other Bed Rail.

4. Position and connect the Footboard to the other end of the Bed Rails as in previous Steps.

5. Carefully align the Footboard to be 'square' with the Headboard. Using the Open Wrench (J) tighten all Hex Nuts attaching the Side Rails to the Headboard and Footboard.

6. Attach the Slat Support Legs (D) to the Wood Slats (C).

7. Attach the Wood Slats to the Bed Rails using the Wood Screws (K) and your Phillips Screwdriver. The levelers located at the bottom of the Support Legs can be adjusted if necessary.

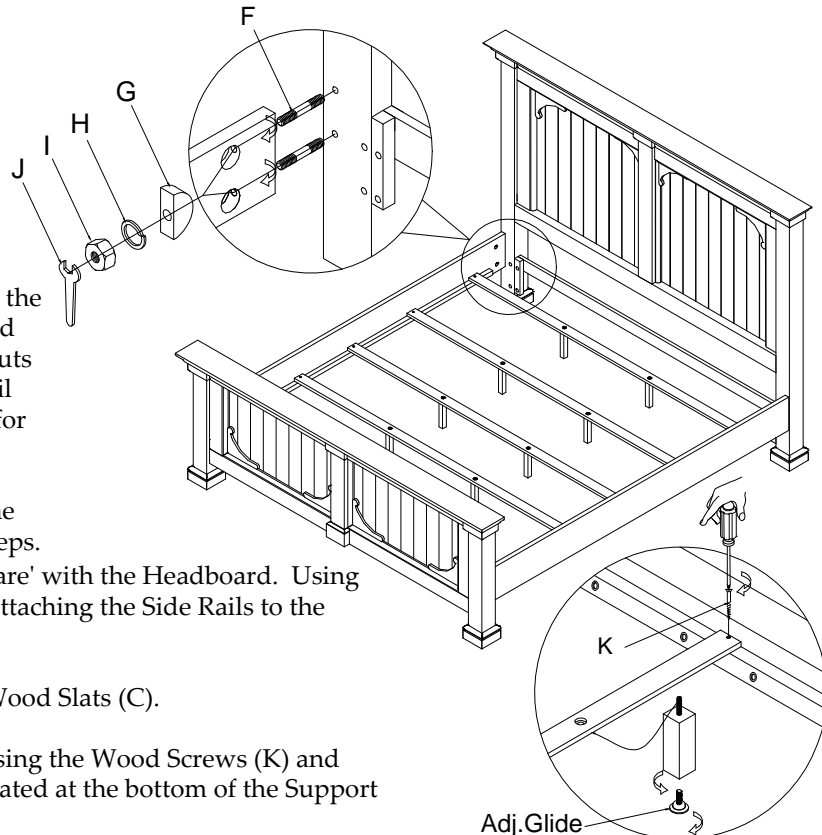

**6/6 King Bed**

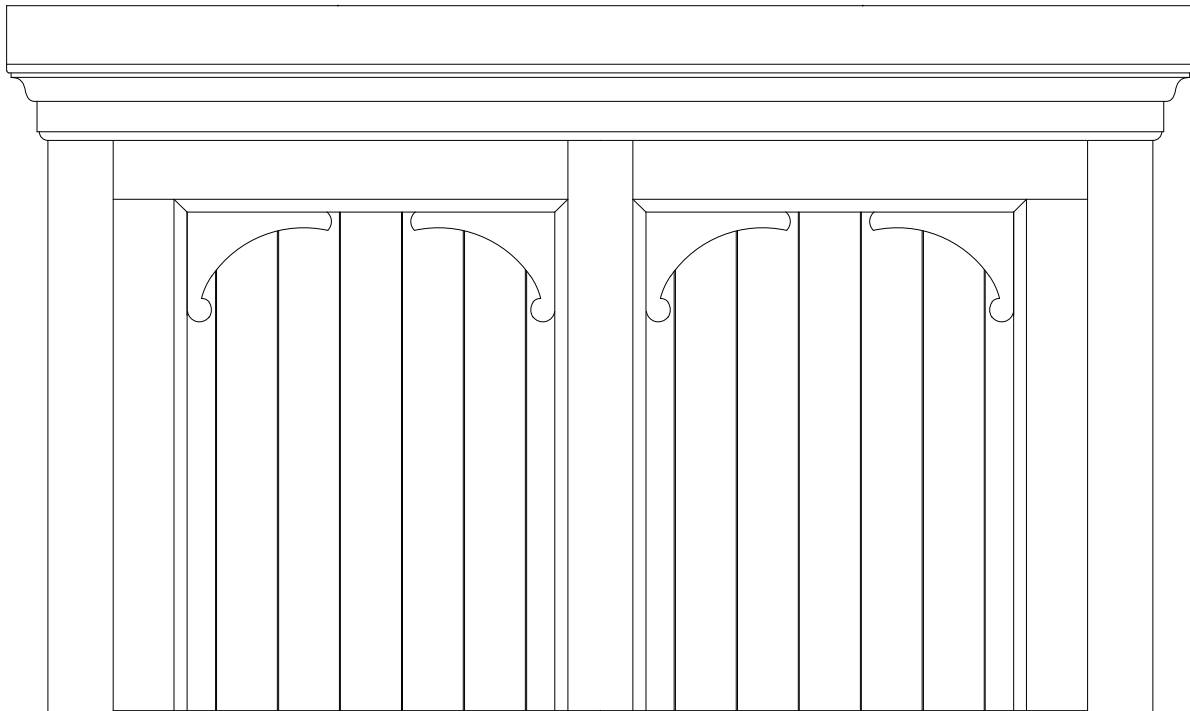

USE THESE HOLES FOR ATTACHING WOOD SIDE RAILS.  
ALL HARDWARE IS INCLUDED WITH THE SIDE RAILS

USE THESE HOLES FOR ATTACHING A CALIFORNIA  
KING SIZE (6/0) METAL BED FRAME

CUSTOMER TO PROVIDE 5/16 X 1-1/2" LONG BOLTS, NUTS  
& WASHERS TO CONNECT THE METAL BED FRAME

USE THESE HOLES FOR ATTACHING AN EASTERN KING  
SIZE (6/6) METAL BED FRAME

CUSTOMER TO PROVIDE 5/16 X 4-1/2" LONG BOLTS, NUTS  
& WASHERS TO CONNECT THE METAL BED FRAME

