

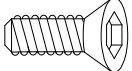





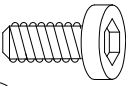

Components and Hardware List

<p>4mm Allen Wrench</p>  <p>A 1 pc.</p>	<p>M1/4" x 5/8" Flat Head Bolt</p>  <p>B 12 pcs.</p>	<p>Ø14 x 2mm Plastic Spacer</p>  <p>C 6 pcs.</p>	<p>Ø14 x 6mm Plastic Spacer</p>  <p>D 8 pcs.</p>
<p>M1/4" x 1-1/4" Allen Head Bolt</p>  <p>E 2 pcs.</p>	<p>1/4" Spring Washer</p>  <p>F 2 pcs.</p>	<p>1/4" x 16mm Flat Washer</p>  <p>G 2 pcs.</p>	<p>Anti-Tip Restraint Set</p>  <p>H 1 pc.</p>
<p>Screw M4*50MM</p>  <p>I 2 pcs.</p>	<p>Shelf Strap</p>  <p>J 2 pcs. each size</p>	<p>Leaning TV Stand Without bottom shelf</p>  <p>K 1 pc.</p>	<p>Bottom Shelf</p>  <p>L 1 pc.</p>

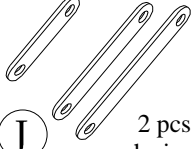

23740 Leaning TV Stand

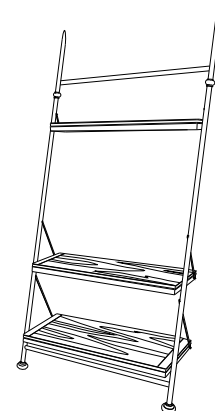
Be sure to check all packing material carefully for small parts, which may have come loose inside the carton during shipment.

Caution: In order to have a safe product, this TV Stand must be securely attached to the customer's wall.

To prevent possible scratches or damages, assemble the Bookcase on a soft surface such as a blanket or carpet, or it's own packaging materials.

Note:

When attaching the Shelf Straps, use the shortest strap on the top shelf and progressively longer straps on each shelf below.

This TV Stand must be securely attached into a stud located inside the wall it will be leaning against. When stood upright in position, the back edge of the shelves must be against the wall behind the TV Stand.

Determine approximately where the TV Stand will be located and using your stud-finder or another method, locate a stud directly behind two of the holes in the metal frame under the back of the upper shelf. Mark the wall through the holes then temporarily move the TV Stand aside, bore a 3/32 diameter pilot hole into the wall for each screw, move TV Stand back into position and attach to the wall using the 2" (50mm) long Wood Screws (H) and your Phillips Screwdriver, going through the holes at the back of the metal frame underneath the Top Shelf.

Another option is to use the Anti-Tip Restraint (G) provided, attaching one metal strap to the bottom of the Top Shelf and the other metal strap to a stud inside the wall, and securing with the nylon strap included. Please refer to Page 3 on the instructions.

Caution: In order to have a safe product, this TV Stand must be securely attached to the customer's wall.

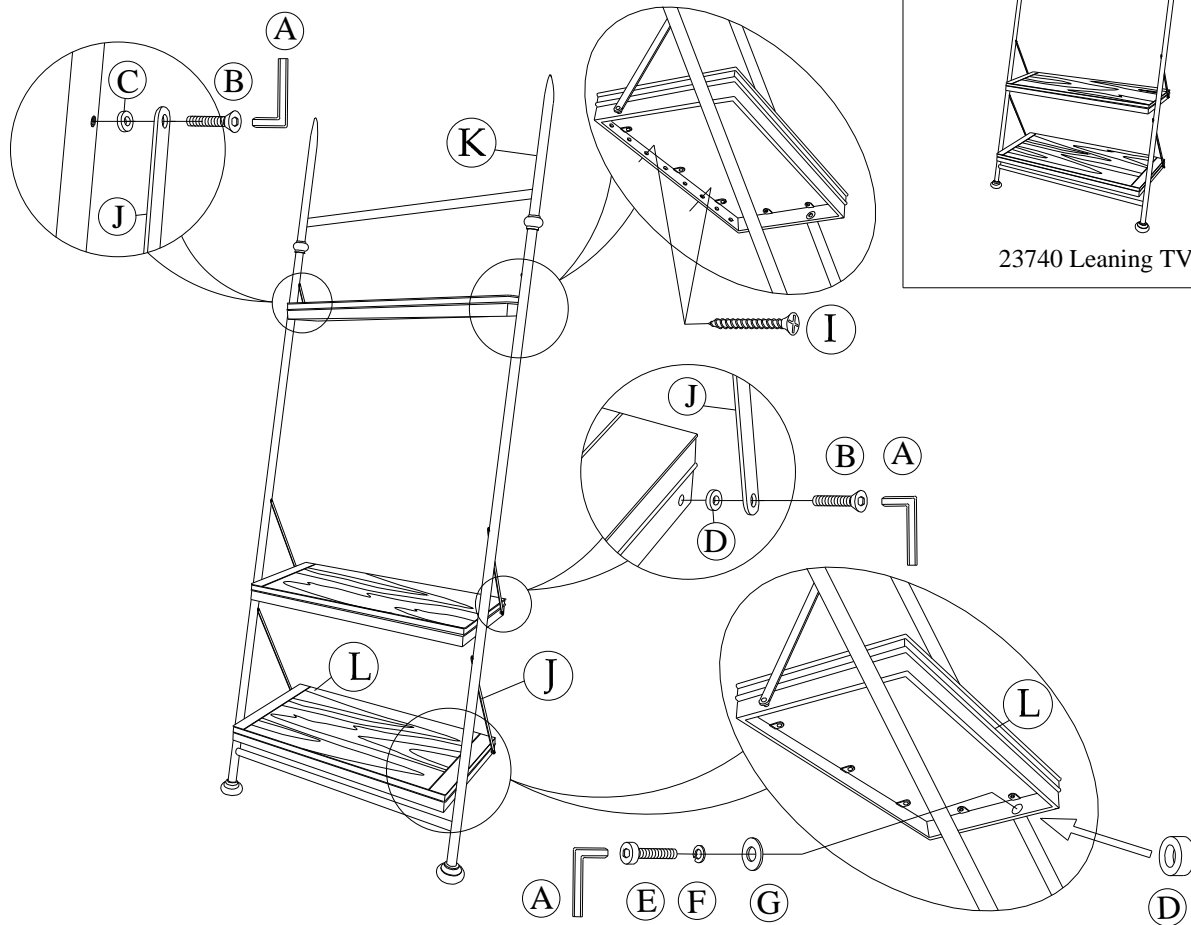

23740 Leaning TV Stand

1. Pivot each of the three upper shelves open and connect to the Legs using the Shelf Straps (J), Flat Head Bolt (B) and 6mm thick Plastic Spacer (D) between the Shelf and Strap. Use the same Bolt and 2mm thick Plastic Spacer (C) between the top of the Strap and the Leg. Do not fully tighten the Bolts until all shelves are in position.
2. Attach the Bottom Shelf (L) between the Legs of the Leaning Bookcase, using Flat Washer (G), Spring Washer (F), and Allen Head Bolt (E), from underneath the shelf. Install the Bolt through a 6mm thick Plastic Spacer (D) on each side, between the outside of the Bottom Shelf and Leg. Connect the longest Shelf Strap sat the back, using a Flat Head Bolt and 6mm thick Plastic Spacer between the Shelf and Strap. Use the same Bolt and 2mm thick Plastic Spacer (C) between the top of the Strap and the Leg.
3. Tighten all the Bolts using the Allen Wrench (A).

There are levelers installed in the bottom of the Legs which can be adjusted if necessary to compensate for uneven floors.

Notice: Riverside Furniture Corp. recommends that steps be taken for certain furniture items to prevent or minimize the risk of tip-over. This furniture is equipped with Tip-over Restraint Hardware for use to minimize this risk, if used. Please follow below installation steps. Riverside Furniture Corp. recommends that parents and guardians periodically visit the U.S. Consumer Product Safety Commission (CPSC) website at <http://www.cpsc.gov/> and stay up to date on all issues related to children's product safety.

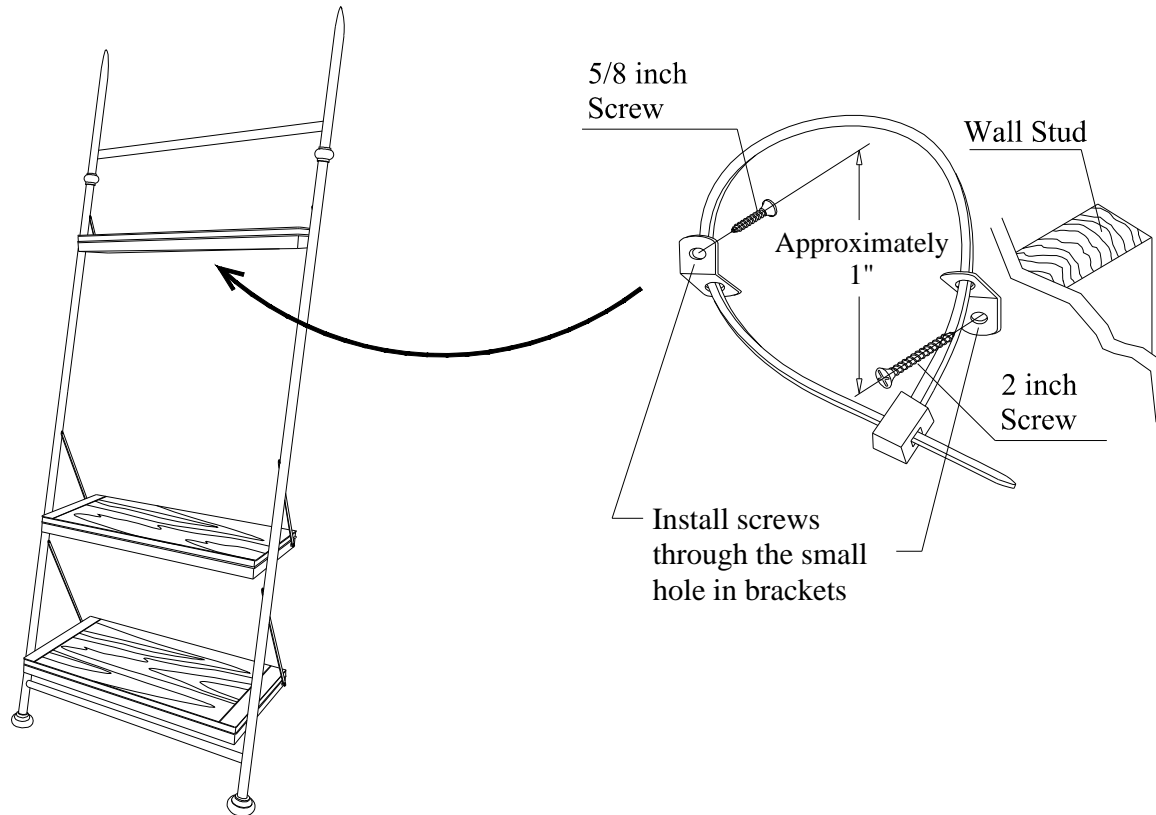

1. Temporarily locate the furniture to near it's final location in the room leaning against the wall. Locate a wall stud behind your furniture and also mark the stud's location underneath the Top Shelf of your furniture.
2. Firmly attach one bracket to the stud approximately 1" below the Top Shelf with the **2 inch long** Wood Screws provided. It may be necessary to drill 3/32 dia. pilot holes for the screws.
3. Firmly attach the other bracket underneath the Top Shelf using the **5/8 inch long** Wood Screws.
4. Move the furniture into its final position, taking care to line up the wall bracket with the furniture bracket. Thread a strap through the bracket as shown in the illustration. Tighten strap until snug but do not over tighten.

Caution: Riverside Furniture Corp. assumes no liability for improper installation or excessive loads placed on screws, brackets or straps. Failure to detach this restraint before moving furniture may result in personal injury and property damage.

Warning: This tip-over restraint is not to be a substitute for proper adult supervision. Do not allow children to climb on furniture. Items left on top of the TV and furniture, such as toys, remote controls and treats might tempt young children to climb. Push the TV as far back as possible from the front of its stand. Place electrical cords out of a child's reach, and teach children not to play with the cords.