

USE THESE HOLES FOR ATTACHING WOOD SIDE RAILS. ALL HARDWARE IS INCLUDED WITH THE SIDE RAILS

USE THESE HOLES FOR ATTACHING A CALIFORNIA KING SIZE (6/0) METAL BED FRAME

CUSTOMER TO PROVIDE 5/16 X 2" LONG BOLTS, NUTS & WASHERS TO CONNECT THE METAL BED FRAME

USE THESE HOLES FOR ATTACHING AN EASTERN KING SIZE (6/6) METAL BED FRAME

CUSTOMER TO PROVIDE 5/16 X 2" LONG BOLTS, NUTS & WASHERS TO CONNECT THE METAL BED FRAME

The Headboard may be used alone with an Eastern King or California King Metal Bed Frame

OR

Set up as a 6/6 King Standard Bed

OR







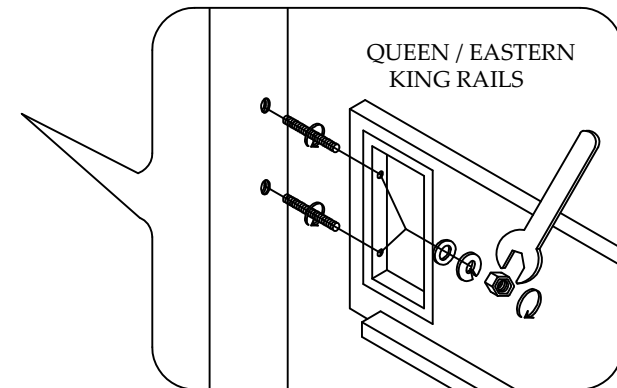

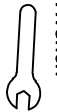
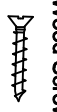

Set up as a 6/0 California Standard Bed

OR

As a 6/6 King Storage Bed



Parts List

M5/16" Spring Washer  (A) 16 pcs.	M5/16" Hex Nut  (B) 8 pcs.	M5/16" x 3-1/2" All-thread Bolt  (C) 8 pcs.	5/0 Queen Panel Headboard #93071-4/6-5/0 Queen Panel Headboard #93072-5/0 Queen Panel Footboard & Slats #93077-5/0-6/6 Panel Bed Rails	6/6 King Panel Bed Components #93075-6/6 King Panel Headboard #93076-6/6 King Panel Footboard & Slats #93077-5/0-6/6 Panel Bed Rails
M5/16" Open Wrench  (D) 1pc.	#8 x 1-1/4" Wood Screw  (E) 16 pcs.	Slat Support Leg  4 pcs. for 5/0 8 pcs. for 6/6 (F) 1 pc.	5/0 Queen Panel Bed Components #93071-4/6-5/0 Queen Panel Headboard #93072-5/0 Queen Panel Footboard & Slats #93077-5/0-6/6 Panel Bed Rails	6/6 King Panel Bed Components #93075-6/6 King Panel Headboard #93076-6/6 King Panel Footboard & Slats #93077-5/0-6/6 Panel Bed Rails
Wood Slat  5/0 6/6 (G) 4 pcs.	Back Post  (H) 1 Pair	Bottom Rail  (I) 1 pc.	5/0 Queen Panel Bed Components #93071-4/6-5/0 Queen Panel Headboard #93072-5/0 Queen Panel Footboard & Slats #93077-5/0-6/6 Panel Bed Rails	6/6 King Panel Bed Components #93075-6/6 King Panel Headboard #93076-6/6 King Panel Footboard & Slats #93077-5/0-6/6 Panel Bed Rails
Headboard Panel  (J) 1 pc.	5mm Allen Wrench  (K) 1 pc.	M5/16" x 1-3/8" Allen Head Bolt  (L) 8 pcs.	5/0 Queen Panel Bed Components #93071-4/6-5/0 Queen Panel Headboard #93072-5/0 Queen Panel Footboard & Slats #93077-5/0-6/6 Panel Bed Rails	6/6 King Panel Bed Components #93075-6/6 King Panel Headboard #93076-6/6 King Panel Footboard & Slats #93077-5/0-6/6 Panel Bed Rails
M5/16" Flat Washer  (M) 8 pcs.			5/0 Queen Panel Bed Components #93071-4/6-5/0 Queen Panel Headboard #93072-5/0 Queen Panel Footboard & Slats #93077-5/0-6/6 Panel Bed Rails	6/6 King Panel Bed Components #93075-6/6 King Panel Headboard #93076-6/6 King Panel Footboard & Slats #93077-5/0-6/6 Panel Bed Rails

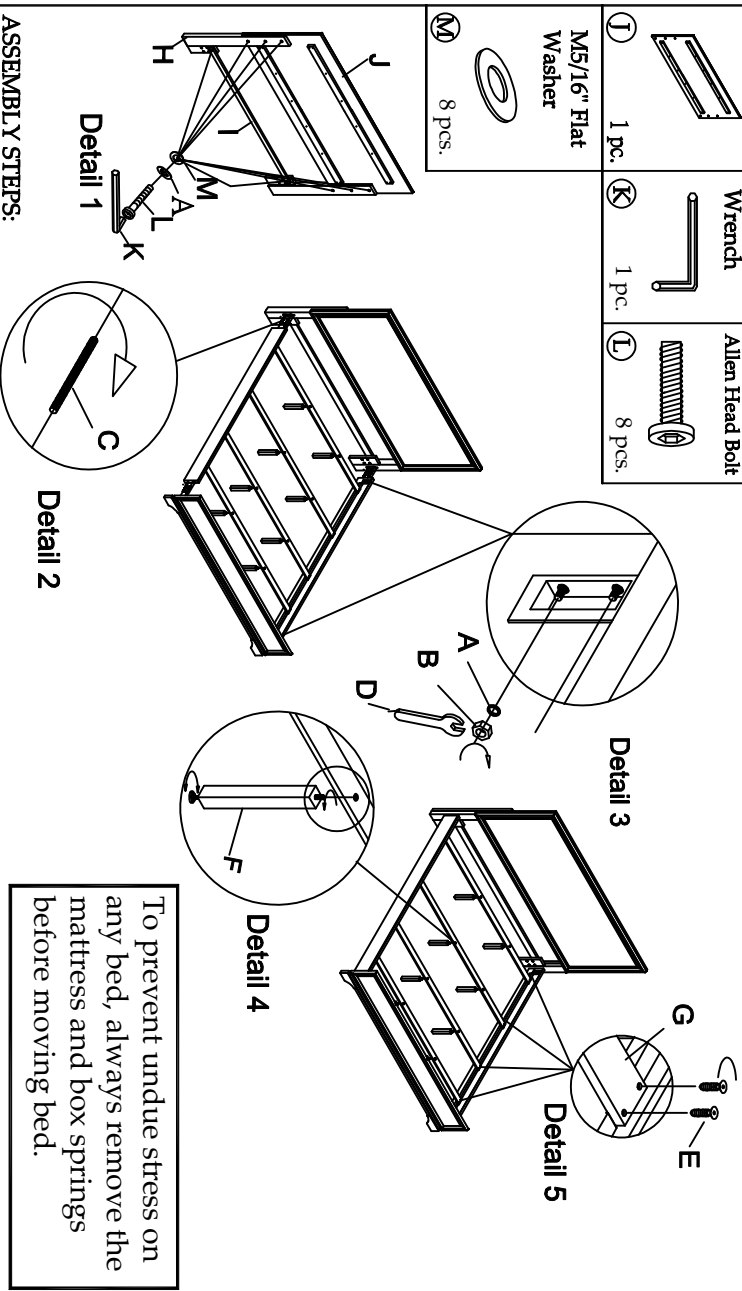









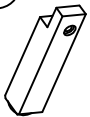
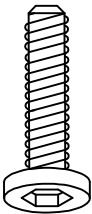

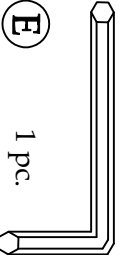
To prevent undue stress on any bed, always remove the mattress and box springs before moving bed.

ASSEMBLY STEPS:

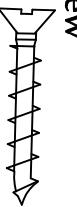
1. Place the Headboard Panel(J) face down on a clean and soft surface.
2. Assemble the Back Posts(F1) to the HB Panel(J) using the Allen Head Bolts(L), Spring washers(A) and Flat washers(M). Tighten with the Allen Wrench(K).
3. Assemble the Bottom Rail(I) to the Back Posts(F1) using the Allen Head Bolts(L), Spring washers(A) and Flat Washers(M).
4. Install the eight All-Thread Bolts (C) into the threaded metal plates mounted on the Headboard and Footboard posts.
5. Gently lean the Headboard against the wall where the completed Bed will be located in the room.
6. Position one end of one Bed Rail onto the All-Thread Bolts and fasten with the Spring Washers (A) and Hex Nuts (B). Only partially tighten the Hex Nuts until the Footboard has been connected. Repeat for other Bed Rail.
7. Position and connect the Footboard to the other end of the Bed Rails as in previous Step.
8. Carefully align the Footboard to be 'square' with the Headboard. Using the Open Wrench (D) tighten all Hex Nuts attaching the Side Rails to the Headboard and Footboard.
9. Attach the Slat Support Leg (F) to the Wood Slat (G). Attach the Wood Slats to the Bed Rails using the Wood Screws (E) and your Phillips Screwdriver. The levelers located at the bottom of the Support Legs can be adjusted if necessary.

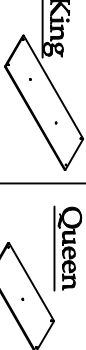
Parts List

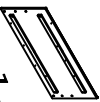
<p>Storage Box Support Leg</p>  <p>(A) 2 pcs.</p>	<p>M1/4" x 1-1/4" Allen Head Bolt</p>  <p>(B) 8 pcs.</p>	<p>M1/4" Spring Washer</p>  <p>(C) 8 pcs.</p>	<p>M1/4" Flat Washer</p>  <p>(D) 8 pcs.</p>
<p>4mm Allen Wrench</p>  <p>(E) 1 pc.</p>	<p>M5/16" x 3-1/2" All-thread Bolt</p>  <p>(F) 8 pcs.</p>	<p>M5/16" Hex Nut</p>  <p>(G) 8 pcs.</p>	<p>M5/16" Spring Washer</p>  <p>(H) 8 pcs.</p>
<p>13mm Open Wrench</p>  <p>(I) 1 pc.</p>	<p>#8 x 1" Wood Screw</p>  <p>(J) 12 pcs.</p>	<p>Support Leg</p>  <p>Queen bed 2 pcs. King bed 4 pcs.</p> <p>(K)</p>	<p>Plywood Platform</p>  <p>King Queen</p> <p>(L) 3 pcs. per bed</p>
<p>Back Post</p>  <p>(M) 1 Pair</p>	<p>Bottom Rail</p>  <p>(N) 1 pc.</p>	<p>Headboard Panel</p>  <p>(O) 1 pc.</p>	

5/0 Queen Panel Bed Components

#93071---4/6-5/0 Queen Panel Headboard

#93074---5/0 Queen Storage Footboard Frame,
Drawers & Plywood Platform

#93080---5/0-6/6 Storage Bed Rails

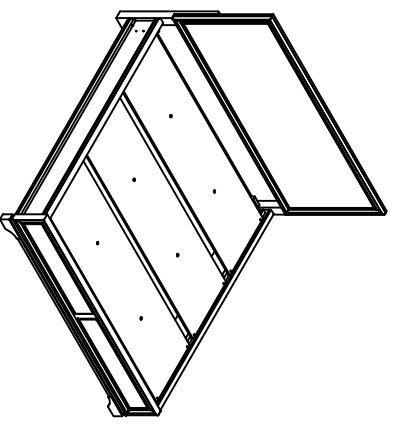

6/6 King Panel Bed Components

#93075---6/0-6/6 King Panel Headboard

#93079---6/0-6/6 King Storage Footboard Frame,
Drawers & Plywood Platform

#93080---5/0-6/6 Storage Bed Rails

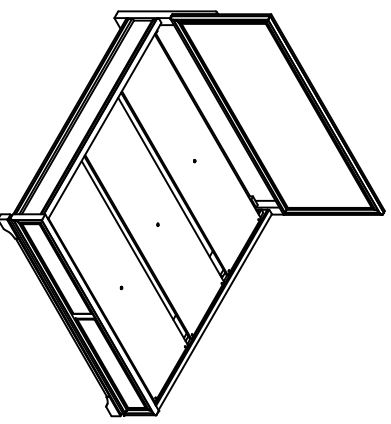

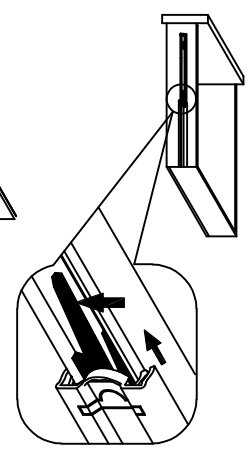

To Remove Drawer:
With the drawer fully open, the drawer slides must be released by pressing the "trigger" located in the slide either up or down, depending on which slide is being released. With both triggers pressed, gently pull the drawer until the slides release. Carefully reinstall the drawers by aligning the channels of the drawer slides and gently pushing the drawers back into the cabinet completely.

ASSEMBLY STEPS:

Assemble bed on a soft surface such as a blanket or carpet. Remove the drawers from the Storage Box and lay them aside.

1. Assemble the Back Posts(M) to the HB Panel (O) using the Allen Head Bolts (Q), Spring Washers (S) and Flat Washers (R). Tighten with the Allen Wrench (P).
2. Assemble the Bottom Rail (N) to the Back Posts using the same bolts, Spring Washers and Flat Washers.
3. Attach the Storage Box Support Legs (A) to the Storage Box using the 1-1/4" long Allen Head Bolts (B), Spring Washers (C) and Flat Washers (D). Tighten with the Allen Wrench (E).
4. Assemble the Storage Box to the Storage Footboard frame using the same Allen Head Bolts (B), Spring Washers (C) and Flat Washers (D) as previous step. Tighten with the Allen Wrench.

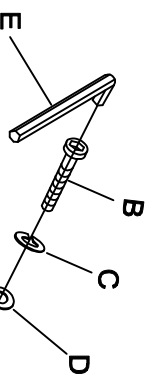
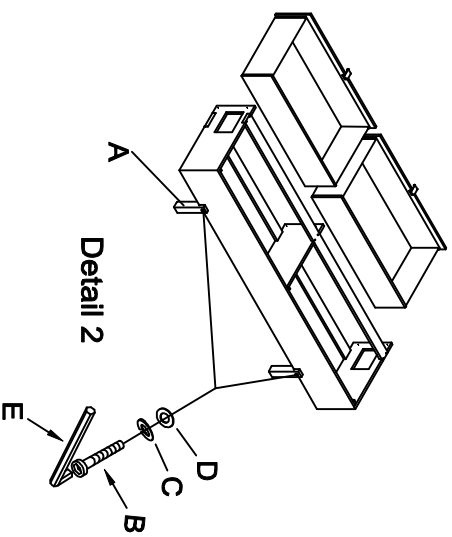
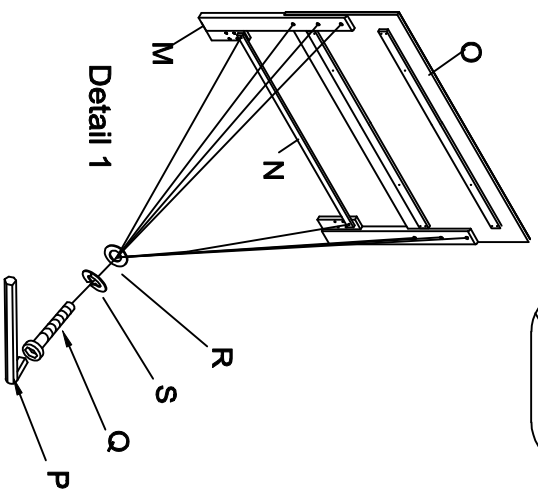

5mm Allen Wrench

(P) 1 pc.

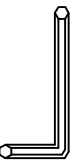

M5/16" x 1-3/8" Allen Head Bolt

(Q) 8 pcs.

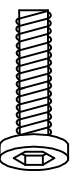

M5/16" Flat Washer

(R) 8 pcs.



M5/16" Spring Washer

(S) 8 pcs.



Detail 3

3. Install the eight All-Thread Bolts (F) into the threaded metal plates mounted on the Headboard and Footboard.
4. Gently lean the Headboard against the wall where the completed Bed will be located in the room.
5. Position one end of one Bed Rail onto the All-Thread Bolts and fasten with the Spring Washers (H) and Hex Nuts (G). Only partially tighten the Hex Nuts until the Footboard has been connected. Repeat for other Bed Rail.
6. Position and connect the Footboard to the other end of the Bed Rails as in previous Step.
7. Carefully align the Footboard to be 'square' with the Headboard. Using the Open Wrench (I) tighten all Hex Nuts attaching the Side Rails to the Headboard and Footboard.
8. Attach the Support Leg (K) to the bottom side of the Plywood Panels. Place the Plywood Panels on top of the Wood Cleats on the Wood Bed Rails.
9. Attach the Plywood Panels using the Wood Screws (J) and your Phillips Screwdriver.
10. Reinstall the Drawers back into the Storage Footboard.

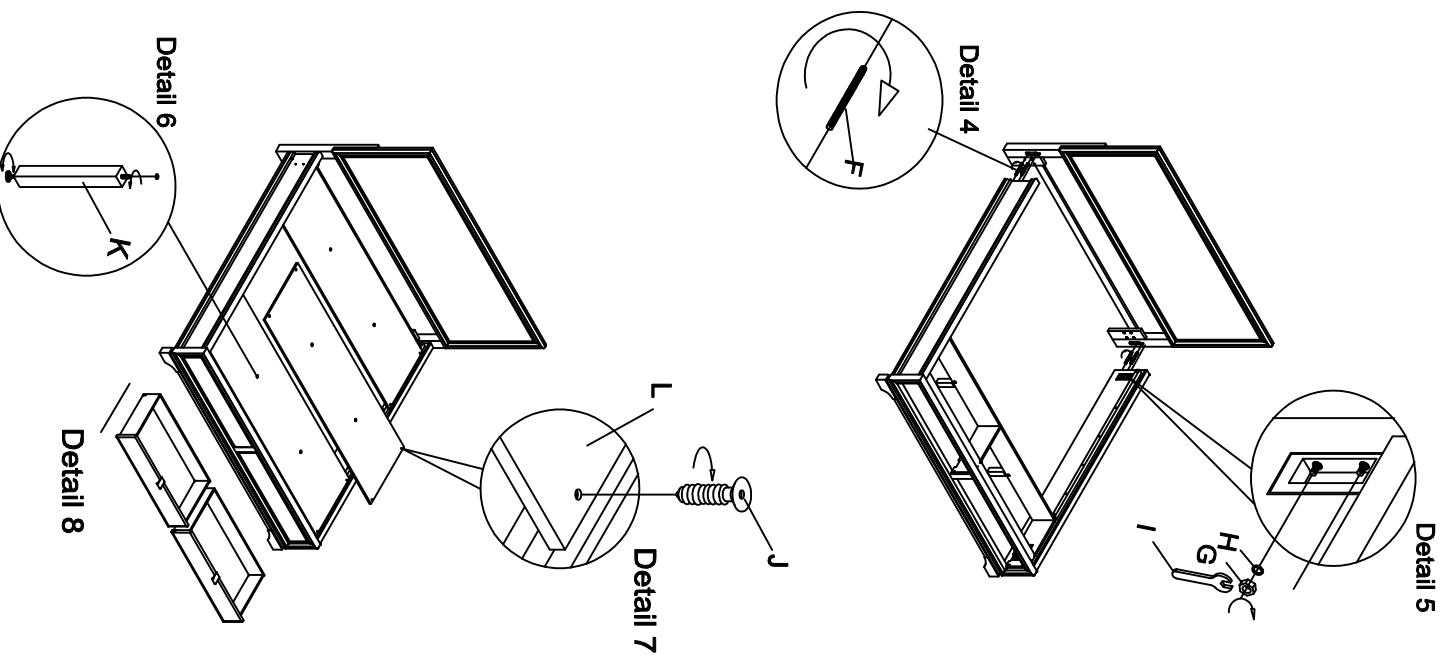

Caution:

To prevent undue stress on any bed frame, always remove the mattress and box springs before moving.