

PART LIST

- 1 Travertine Top
- 2 Leg
- 2 Stretcher
- 1 Grill Shelf

HARDWARE LIST

- 12 Bolts 3/16 x 1/2"
- 12 Screws #10 x 3/4"

TOOLS REQUIRED BUT NOT PROVIDED

- Phillips Screwdriver

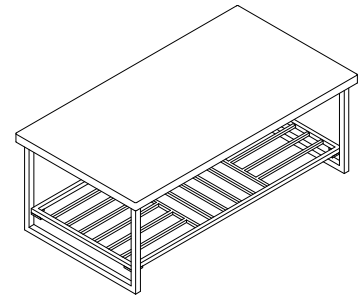

Thank you for purchasing this quality product. Be sure to check all packing material carefully for small parts which may have come loose inside the carton during shipment. Identify and count all parts and compare with parts lists.

It is strongly recommended that this table be assembled by **TWO PEOPLE** to avoid marking or scratching the finish. It is easier to assemble this product upside down.

1. Locate and unpack all of the parts and place them on a soft surface such as a blanket or carpet.
2. Match numbers on base to numbers on top.
3. Place the Travertine Top upside down on a soft surface.
4. Attach Legs to Grill Shelf and Stretchers using 3/16 x 1/2 Bolts as shown. Leave loose.
5. Attach Leg Assembly to Travertine Top using #10 x 3/4 Screws as shown. Tighten Bolts.
6. Turn the completed Table upright.

It is recommended that you periodically check and tighten all parts during the lifetime of the product. Clean with a damp cloth and buff dry with a soft cloth. Use of commercial polishes or waxes is not recommended.

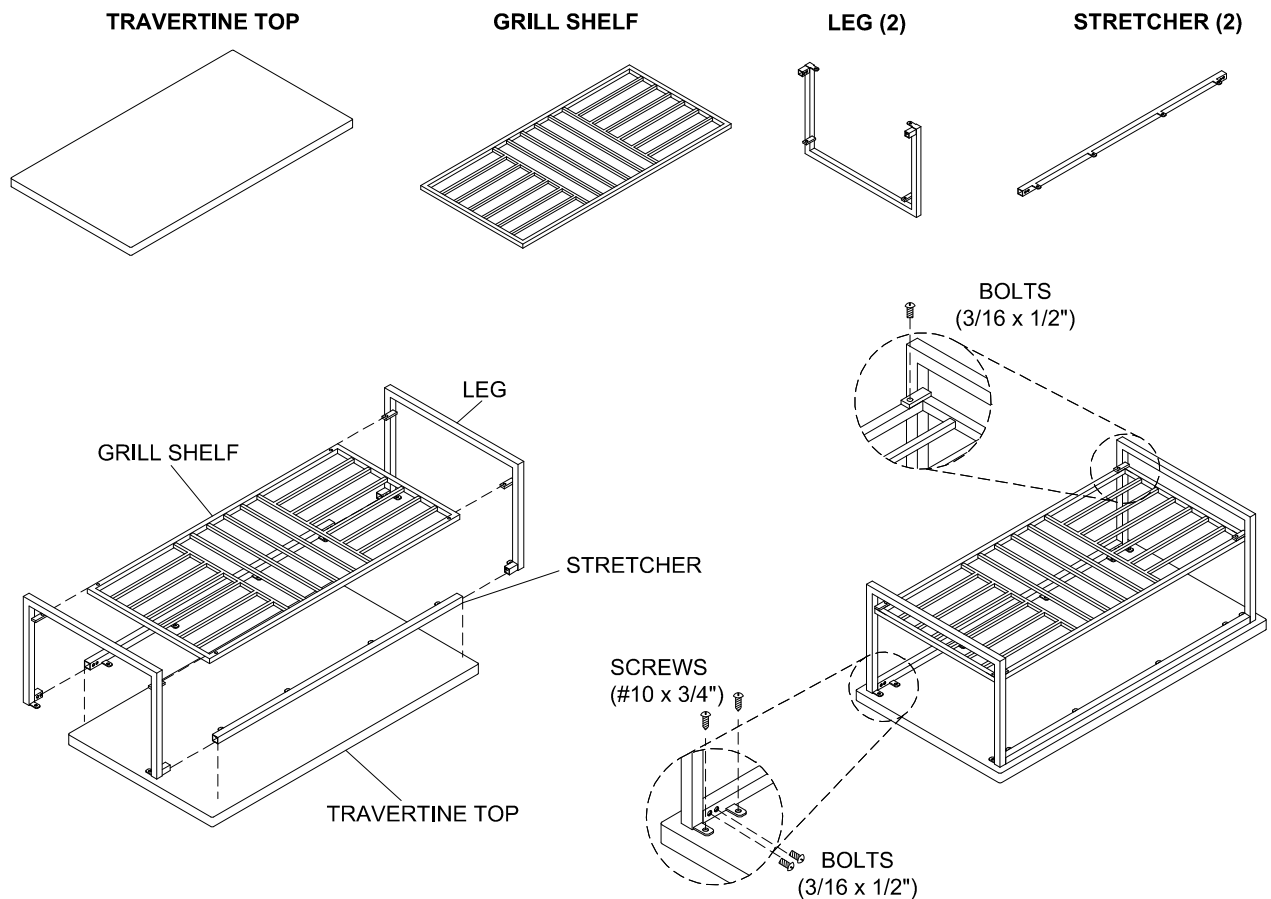

Travertine is a natural, porous material that can be cut, machined and polished. Each piece of travertine has unique natural characteristics that affect the appearance, color and polishing qualities. These are not flaws in quality, but the natural beauty of Travertine. This product has been stained and has a polyurethane top coat; however caution must still be followed. Take care not to scratch, knock, chip or drop. Use coasters when serving food and drinks and under articles that may scratch. Do not place hot items directly on the surface. Avoid contact with glass cleaner, lemon, vinegar, alcohol, acids and oil products. This product is not intended for outdoor use.